



FORD EDGE SUV,
+ wer. USA

08/2015 -

Cat. No. E/A58

E20 E20 55R-01 5193

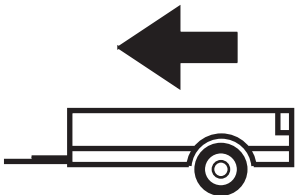



2350kg



120kg

D = 12,00kN

$$D \text{ (kN)} = \frac{\text{MAX kg} \times \text{MAX kg}}{\text{MAX kg} + \text{MAX kg}} \times 0,00981$$

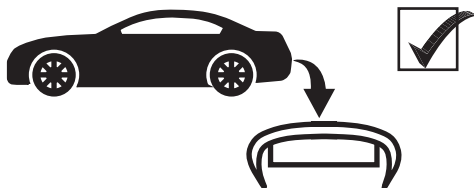



IMIOLA HAK-POL

96-111 KOWIESY, CHOJNATA 23A, POLAND

Tel. + 48 46 831 73 31, fax +48 831 74 29

e-mail: office@imiola.pl, www.imiola.pl

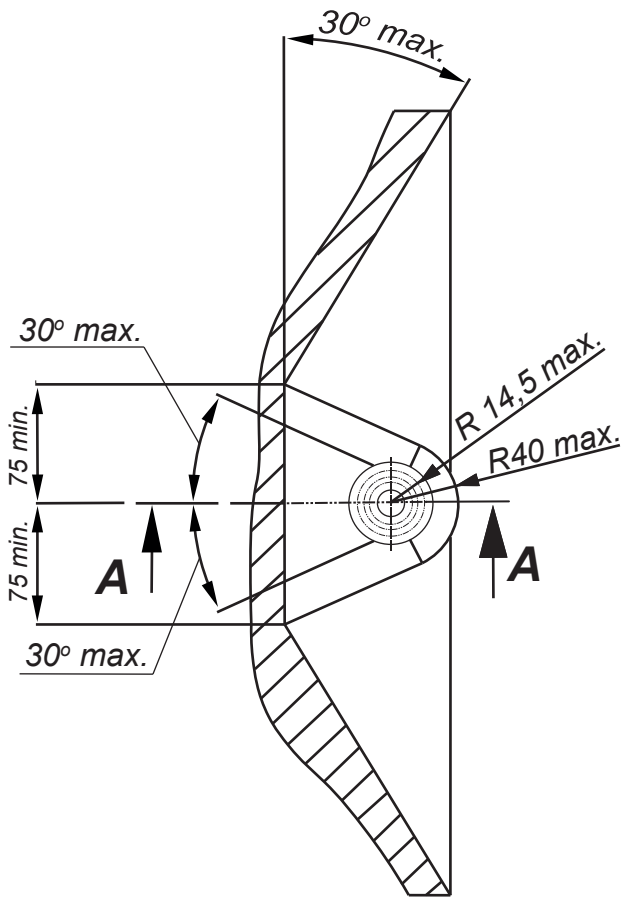

PRZEKRÓJ A-A

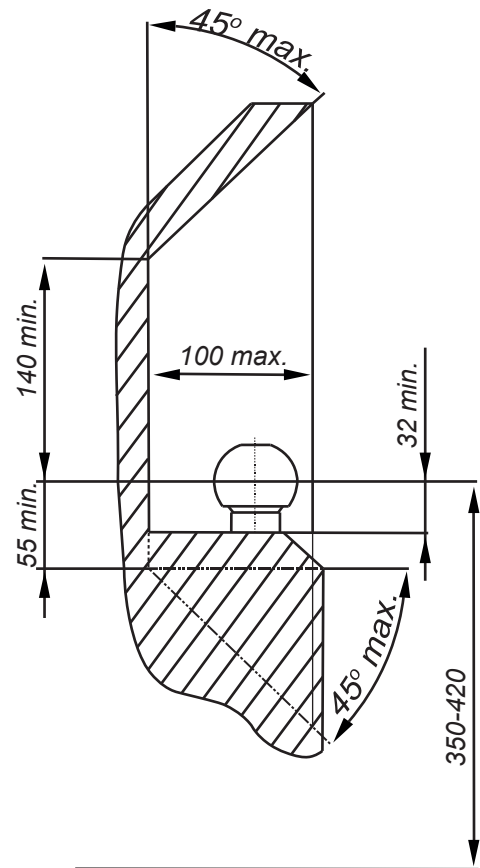

PL Należy zagwarantować przestrzeń swobodną według załącznika VII, rysunek 25a/b Regulaminu EKG ONZ 55.01 przy dopuszczalnym ciężarze całkowitym pojazdu.

F L'espace libre doit être garanti conformément à l'annexe VII, illustration de la réglementation 55.01 CE pour un poids total en charge autorisé du véhicule.

GB The clearance specified in appendix VII, diagram 25a/b of Regulation No. 55.01 UN EU must be guaranteed at laden weight of the vehicle.

D Der Freiraum nach Anhang VII, Abbildung 25a/b der Vorschriften 55.01 EG ist zu gew 25a/bahrleisten bei zulässigem Gesamtgewicht des Fahrzeuges.

Moment skręcający dla śrub i nakrętek (8.8) Torque settings for nuts and bolts (8.8)	
M8	25Nm
M10	55Nm
M12	85Nm
M14	135Nm
M16	195Nm



Nakrętka M12 ; Nut
 Podkł. spręż. 12,2 ; Spring Washer
 Podkł. okr. 13 ; Plain Washer

Śruba M14x50-8.8 ; Bolt
 Podkł. spręż. 14,2 ; Spring Washer
 Podkł. okr. Ø44x Ø15x 3 ; Plain Washer

Śruba M12x40-8.8 ; Bolt

Śruba M14x50-8.8 ; Bolt
 Podkł. spręż. 14,2 ; Spring Washer
 Podkł. okr. Ø44x Ø15x 3 ; Plain Washer

Śruba M14x50-8.8 ; Bolt
 Podkł. spręż. 14,2 ; Spring Washer
 Podkł. okr. Ø44x Ø15x 3 ; Plain Washer

Śruba M12x22-8.8 ; Bolt









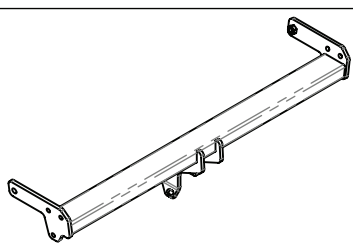
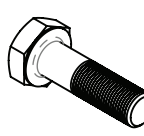
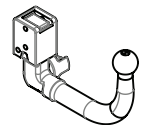

Śruba M12x22-8.8 ; Bolt
 Podkł. spręż. 12,2 ; Spring Washer

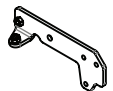
Nakrętka M12 ; Nut
 Podkł. spręż. 12,2 ; Spring Washer
 Podkł. okr. 13 ; Plain Washer

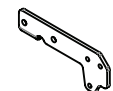
Śruba M12x22-8.8 ; Bolt

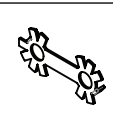
Śruba M14x50-8.8 ; Bolt
 Podkł. spręż. 14,2 ; Spring Washer
 Podkł. okr. Ø44x Ø15x 3 ; Plain Washer

Śruba M12x22-8.8 ; Bolt
 Podkł. spręż. 12,2 ; Spring Washer

	A	x1		M14x50	6
				M12x40	6
				M12x22	6
	B	x1		M12	6
	C	x2		Ø44xØ15x3	6
	D	x1		13	6
	E	x2		14,2	6
				13	8
	F	x1			
	G	x1			

Nakrętka M12 ; Nut
Podkt. spręż. 12,2 ; Spring Washer
Podkt. okr. 13 ; Plain Washer

Śruba M14x50-8.8 ; Bolt
Podkt. spręż. 14,2 ; Spring Washer
Podkt. okr. Ø44x Ø15x 3 ; Plain Washer

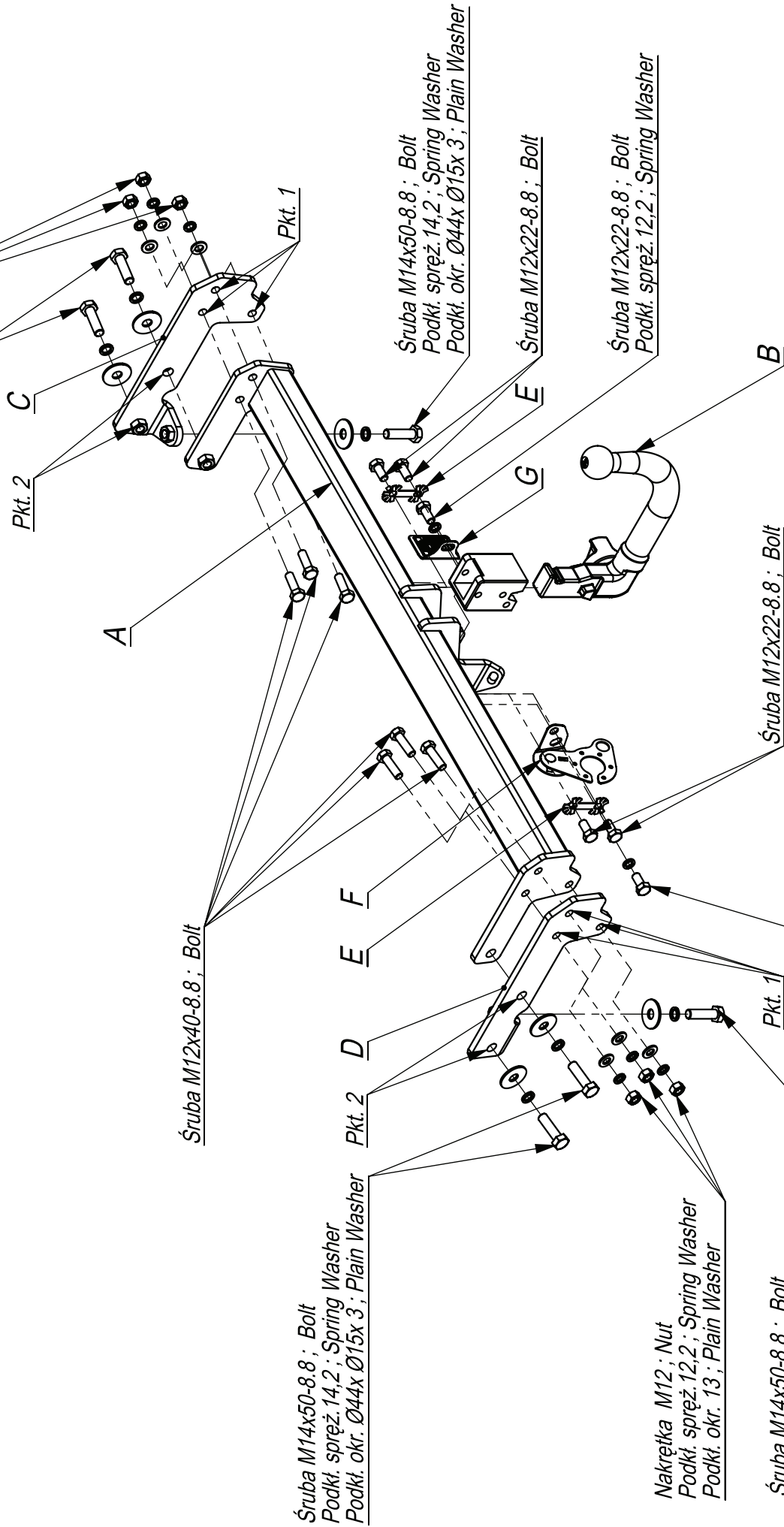

Śruba M14x50-8.8 ; Bolt
Podkt. spręż. 14,2 ; Spring Washer
Podkt. okr. Ø44x Ø15x 3 ; Plain Washer

Nakrętka M12 ; Nut
Podkt. spręż. 12,2 ; Spring Washer
Podkt. okr. 13 ; Plain Washer

Śruba M14x50-8.8 ; Bolt
Podkt. spręż. 14,2 ; Spring Washer
Podkt. okr. Ø44x Ø15x 3 ; Plain Washer

Śruba M12x22-8.8 ; Bolt
Podkt. spręż. 12,2 ; Spring Washer

Nr katalogowy

E/A58

Marka

Ford Edge suv, +wersja USA od 08/2015 ->



96-111 Kowiesy, Chojnata 23 A
tel. +48 46 831 73 31

- Odkręcić zderzak i metalowe wzmocnienie (nie będzie już wykorzystane).
- W osłonie dolnej wykonać wycięcie na szerokość uchwytu kuli.
- Wsunąć elementy C i D do podłużnic i poprzez technologiczne otwory przykręcić śrubami M14x50 8.8 (pkt 2) stosując powiększone podkładki.
- Do elementów C i D przykręcić belkę zaczepu A śrubami M12x40 8.8 (pkt 1). Przykręcić osłonę dolną.
- Przykręcić kulę i blachę gniazda elektrycznego.
- Dokręcić wszystkie śruby z momentem wg tabeli.
- Przykręcić zderzak.
- Podłączyć instalację elektryczną.

- Unscrew the bumper and its metal reinforcement (it will not be used any more).
- Cut out the fragment in the lower shield to put the towball handles.
- Insert the elements C and D in the frame side members and through the technological holes screw with bolts M14x50 8.8 (point 2) using large washers.
- Screw the main bar A to the elements C and D with bolts M12x40 8.8 (point 1).
- Screw the lower shield.
- Fix the ball and electric plate.
- Tighten all the bolts according to the torque setting- see the table.
- Screw the bumper.
- Connect the electric wires.

- Dévissez le pare-chocs et son renfort métallique (il ne sera plus utilisé).
- Découpez le fragment dans le bouclier inférieur pour mettre les poignées de la boule.
- Insérer les éléments C et D dans les longerons du châssis et à travers les trous technologiques visser avec les boulons M14x50 8.8 (point 2) en utilisant de grandes rondelles.
- Visser la barre principale A sur les éléments C et D avec les vis M12x40 8.8 (point 1).
- Visser le blindage inférieur.
- Fixez la boule et la plaque électrique.
- Serrez tous les boulons en fonction du réglage du couple - voir le tableau.
- Visser le pare-chocs.
- Connectez les fils électriques.

- Schrauben Sie die Stoßstange und ihre Metallverstärkung ab (sie wird nicht mehr verwendet).
- Schneiden Sie das Fragment im unteren Schild aus, um die Kugelgriffe zu setzen.
- Setzen Sie die Elemente C und D in die Seitenteile des Rahmens und durch die technologischen Löcher mit den Schrauben M14x50 8.8 (Punkt 2) mit großen Scheiben verschrauben.
- Schrauben Sie die Hauptstange A mit den Schrauben M12x40 8.8 (Punkt 1) an die Elemente C und D.
- Schrauben Sie die untere Abdeckung fest.
- Befestigen Sie den Ball und die elektrische Platte.
- Ziehen Sie alle Schrauben entsprechend der Drehmomenteinstellung fest - siehe Tabelle.
- Schrauben Sie den Stoßfänger fest.
- Schließen Sie die elektrischen Kabel an.

- Desenrosque el parachoques y su refuerzo de metal (no se usará más).
- Recorta el fragmento en el escudo inferior para colocar las asas de la bola de remolque.
- Inserte los elementos C y D en los miembros laterales del marco y a través de los agujeros tecnológicos Atornille con pernos M14x50 8.8 (punto 2) con arandelas grandes.
- Atornille la barra principal A a los elementos C y D con los pernos M12x40 8.8 (punto 1).
- Atornille el escudo inferior.
- Repare la bola y la placa eléctrica.
- Apriete todos los pernos de acuerdo con la configuración de torque: vea la tabla.
- Atornillar el parachoques.
- Conecte los cables eléctricos.

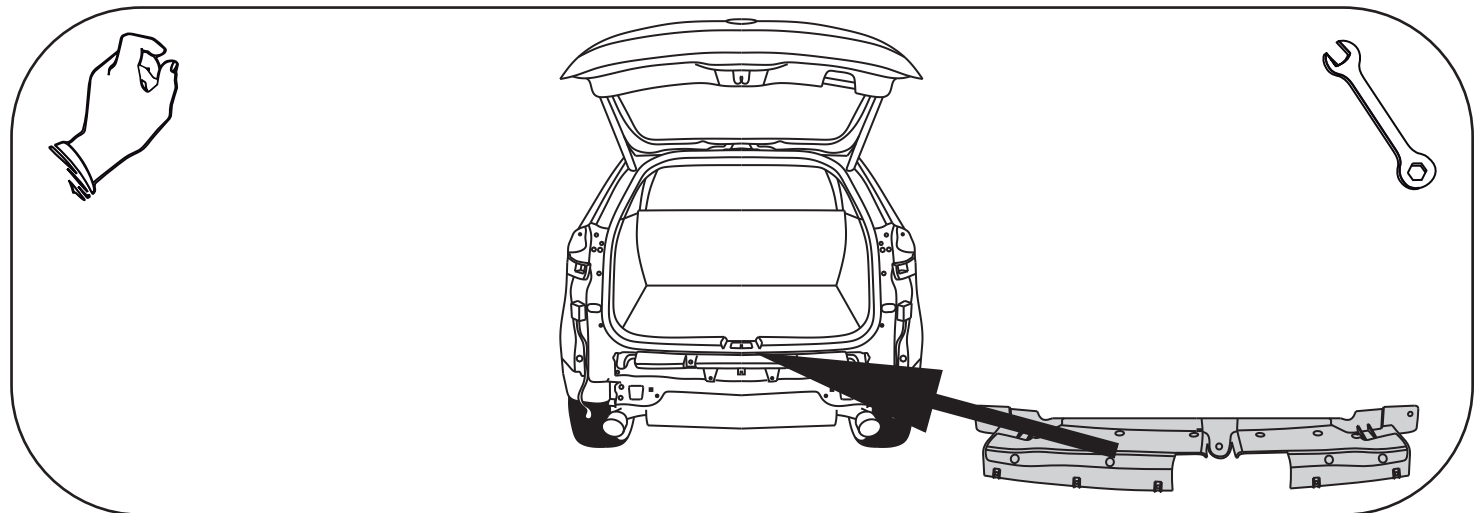
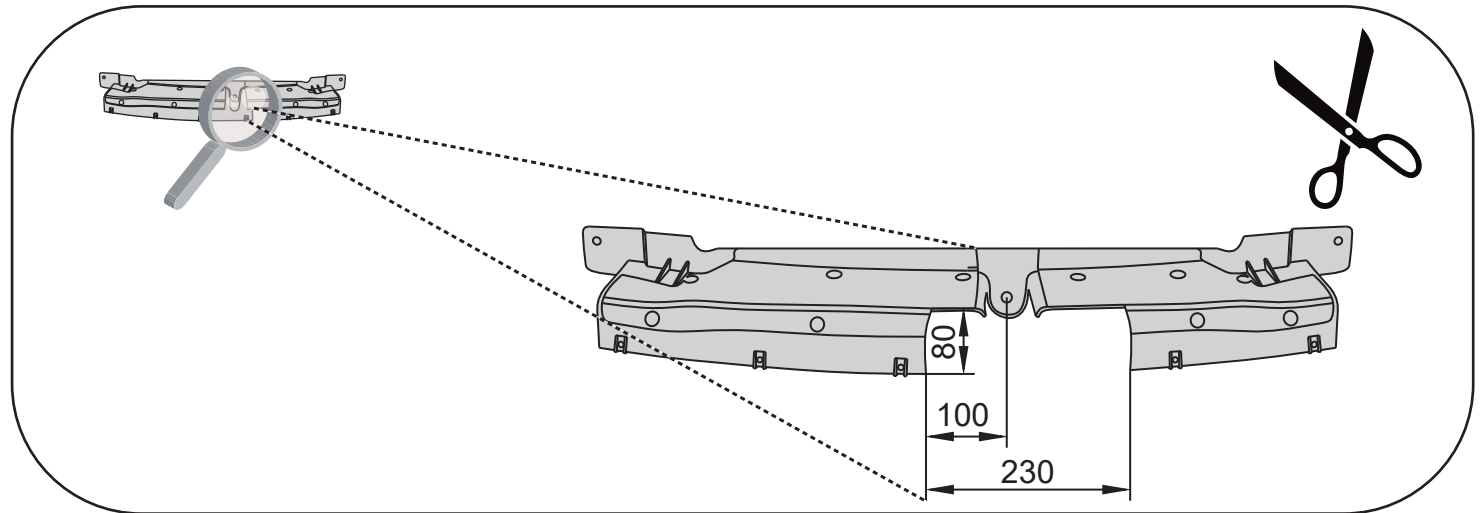
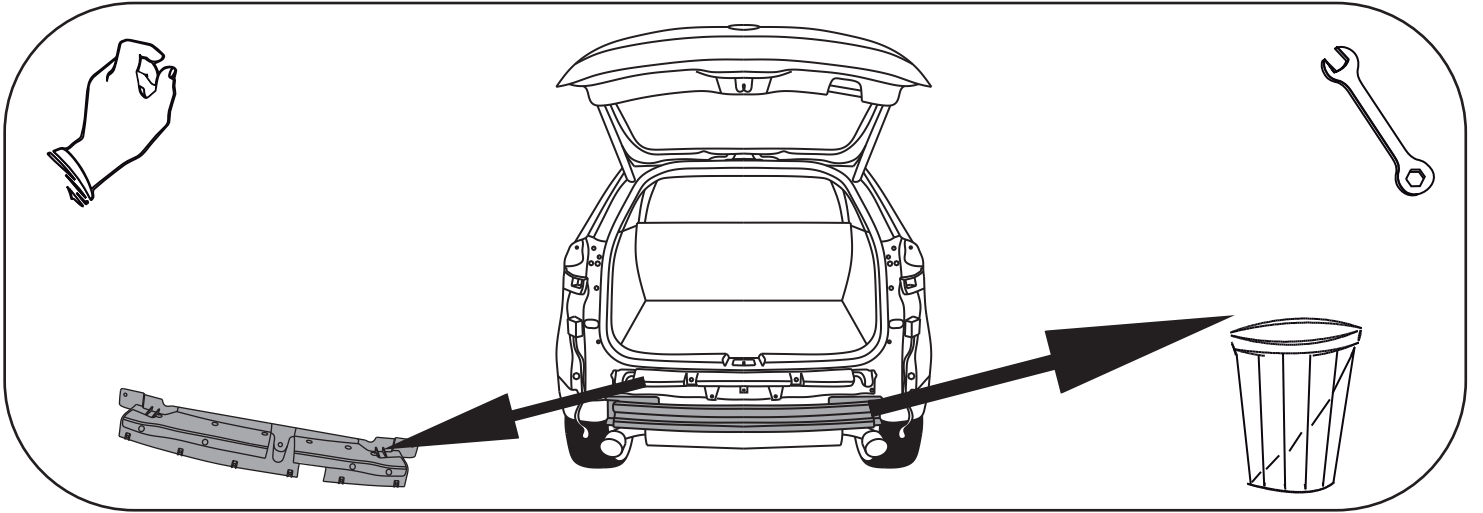
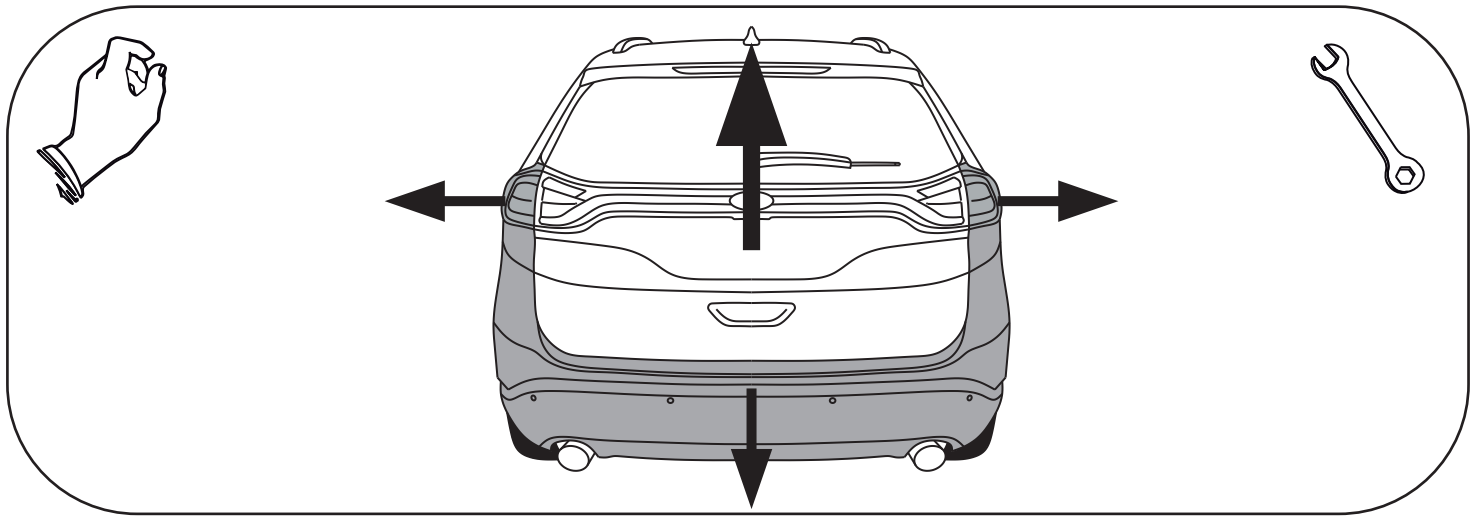

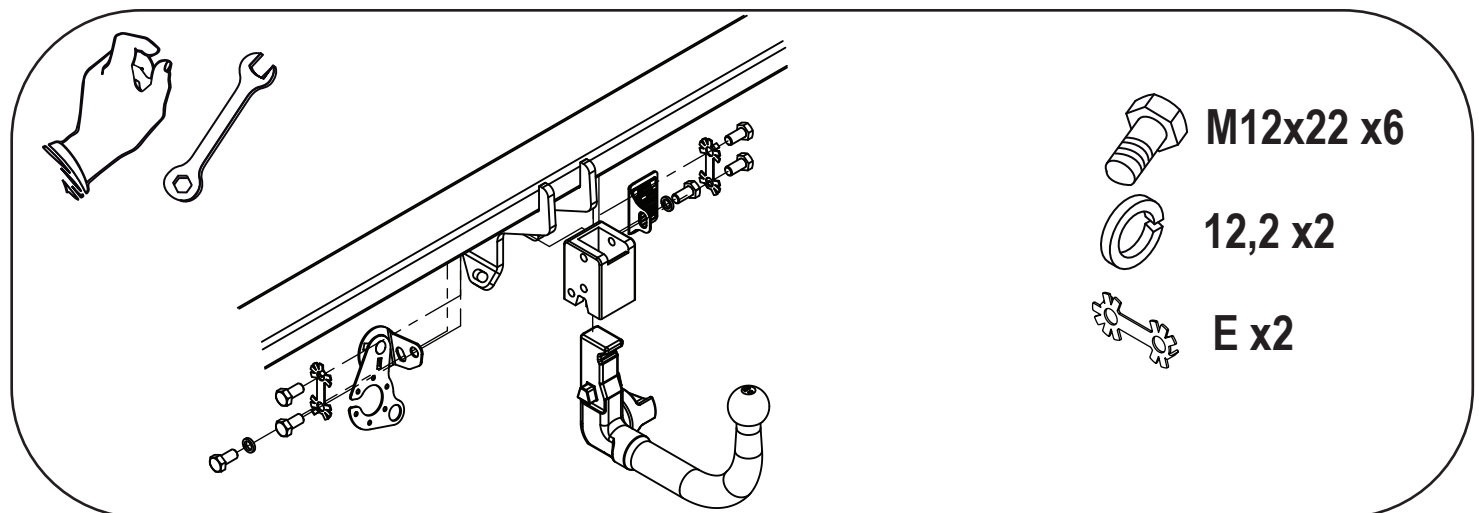
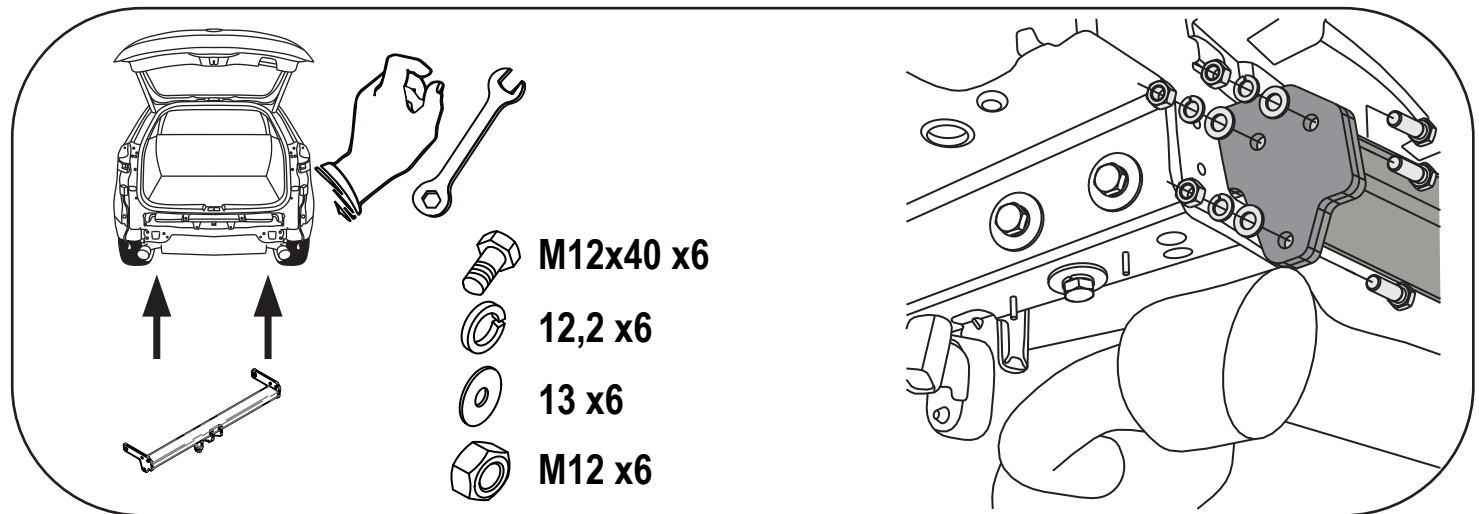
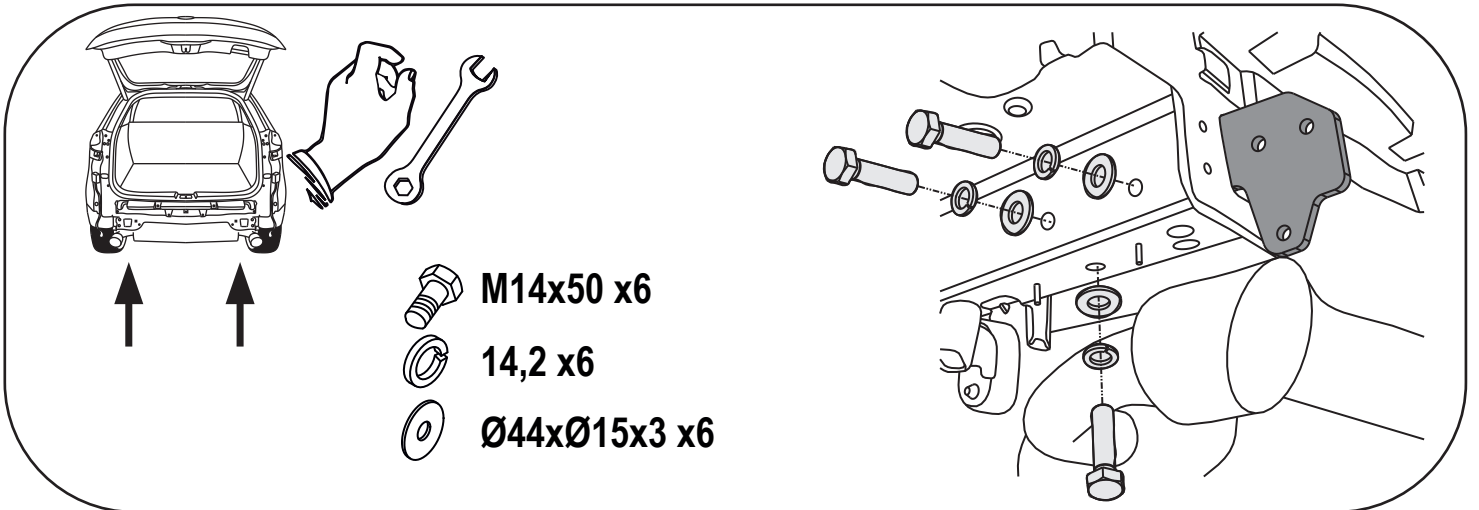
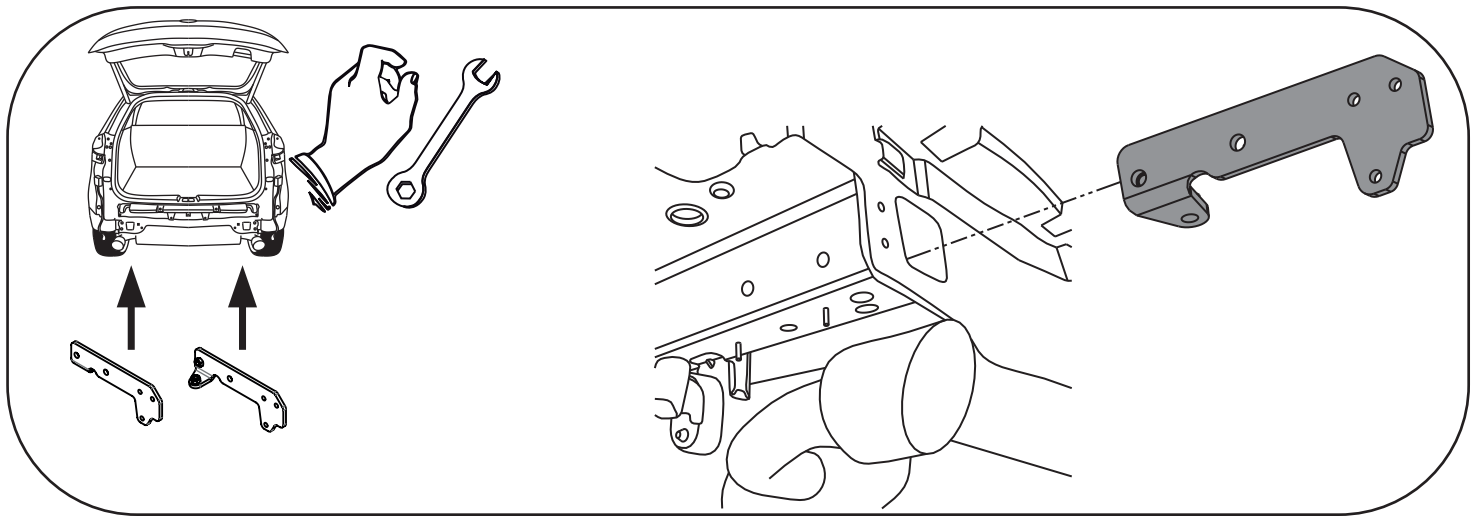



CRIMP

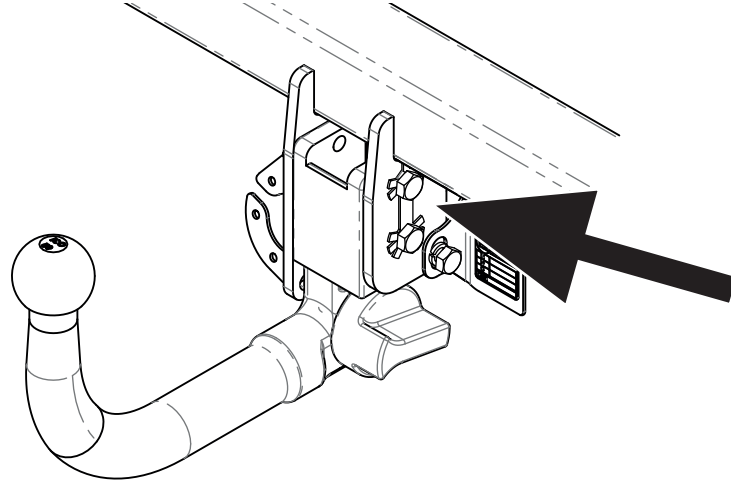
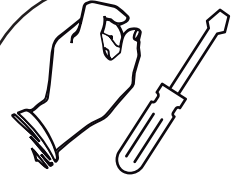
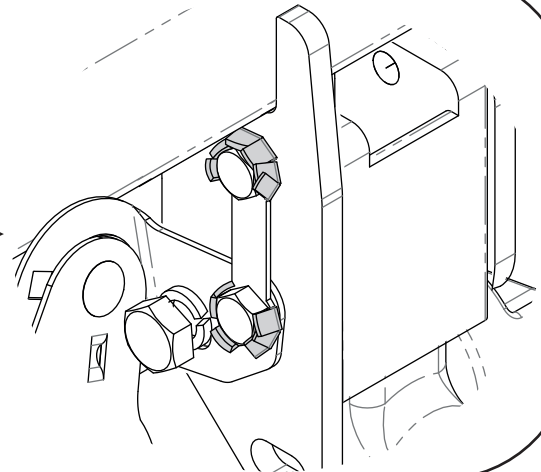
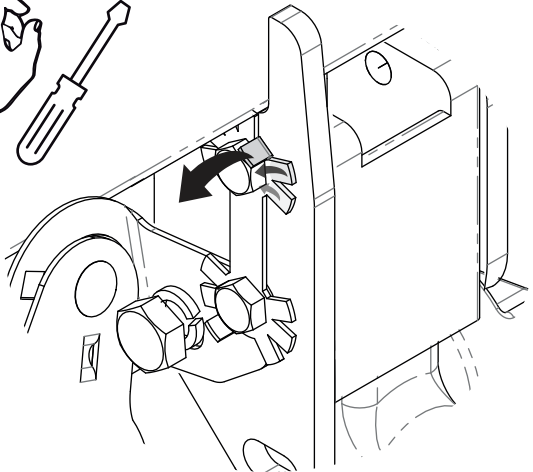
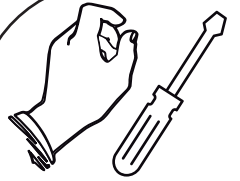
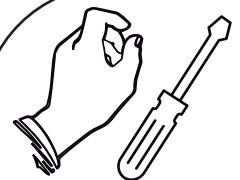
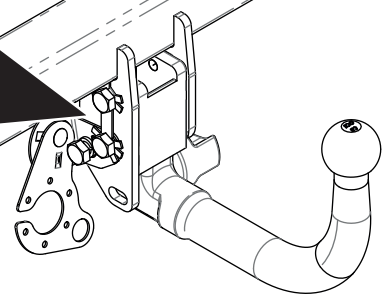

CRIMP

