



PEUGEOT
508 SW estate

03/2011 -

Cat. No. P/A38

E20

E20 55R-01 3046

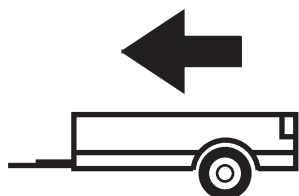

1900kg

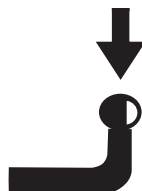

75kg

D = 10,19kN

D (kN) =



MAX kg x MAX kg

x 0,00981



MAX kg + MAX kg

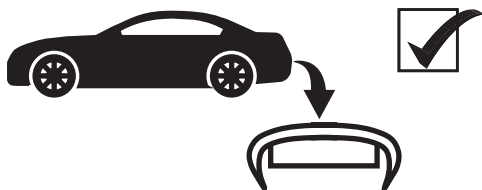

IMIOLA HAK-POL

96-111 KOWIESY, CHOJNATA 23A, POLAND

Tel. + 48 46 831 73 31, fax +48 831 74 29

e-mail: office@imiola.pl, www.imiola.pl

PRZEKRÓJ A-A

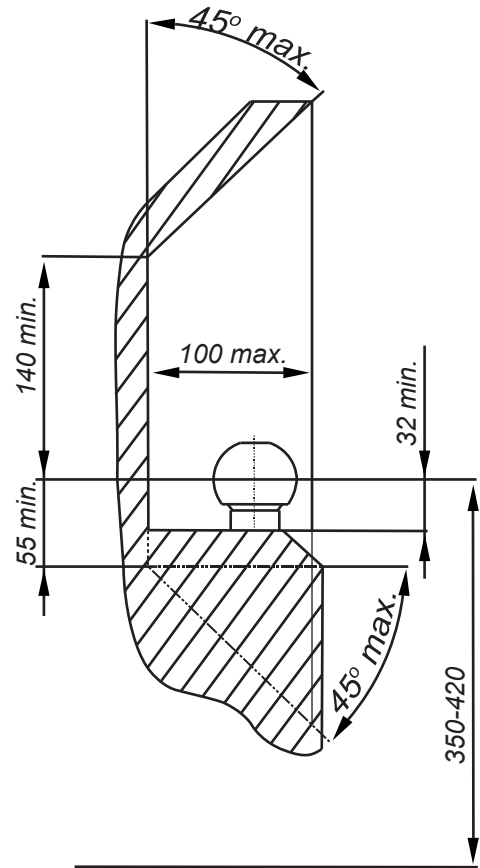
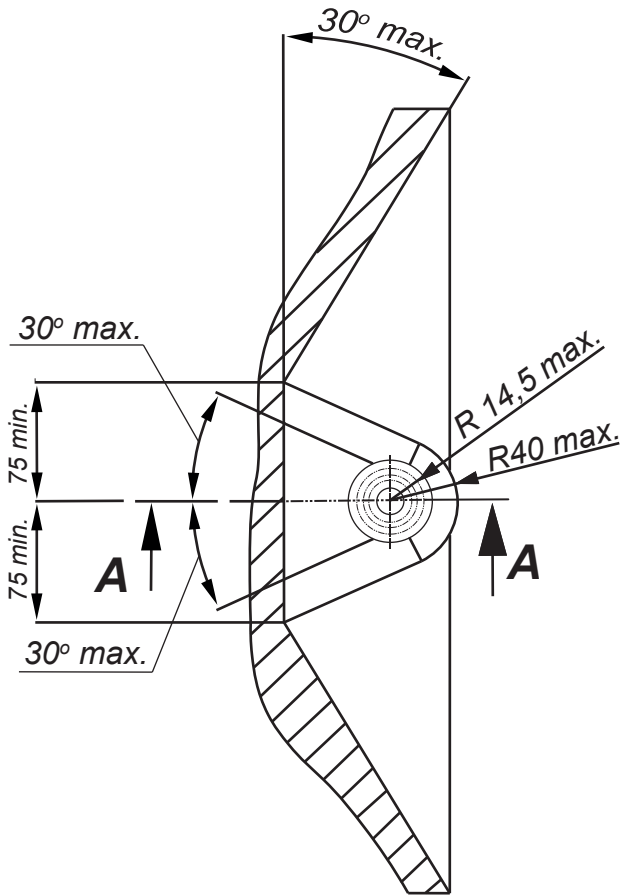

PL Należy zagwarantować przestrzeń swobodną według załącznika VII, rysunek 25a/b Regulaminu EKG ONZ 55.01 przy dopuszczalnym ciężarze całkowitym pojazdu.

F L'espace libre doit être garanti conformément à l'annexe VII, illustration de la réglementation 55.01 CE pour un poids total en charge autorisé du véhicule.

GB The clearance specified in appendix VII, diagram 25a/b of Regulation No. 55.01 UN EU must be guaranteed at laden weight of the vehicle.

D Der Freiraum nach Anhang VII, Abbildung 25a/b der Vorschriften 55.01 EG ist zu gew 25a/bahrleisten bei zulässigem Gesamtgewicht des Fahrzeuges.

| Moment skręcający dla śrub i nakrętek (8.8) Torgue settings for nuts and bolts (8.8) | |
|---|-------|
| M8 | 25Nm |
| M10 | 55Nm |
| M12 | 85Nm |
| M14 | 135Nm |
| M16 | 195Nm |



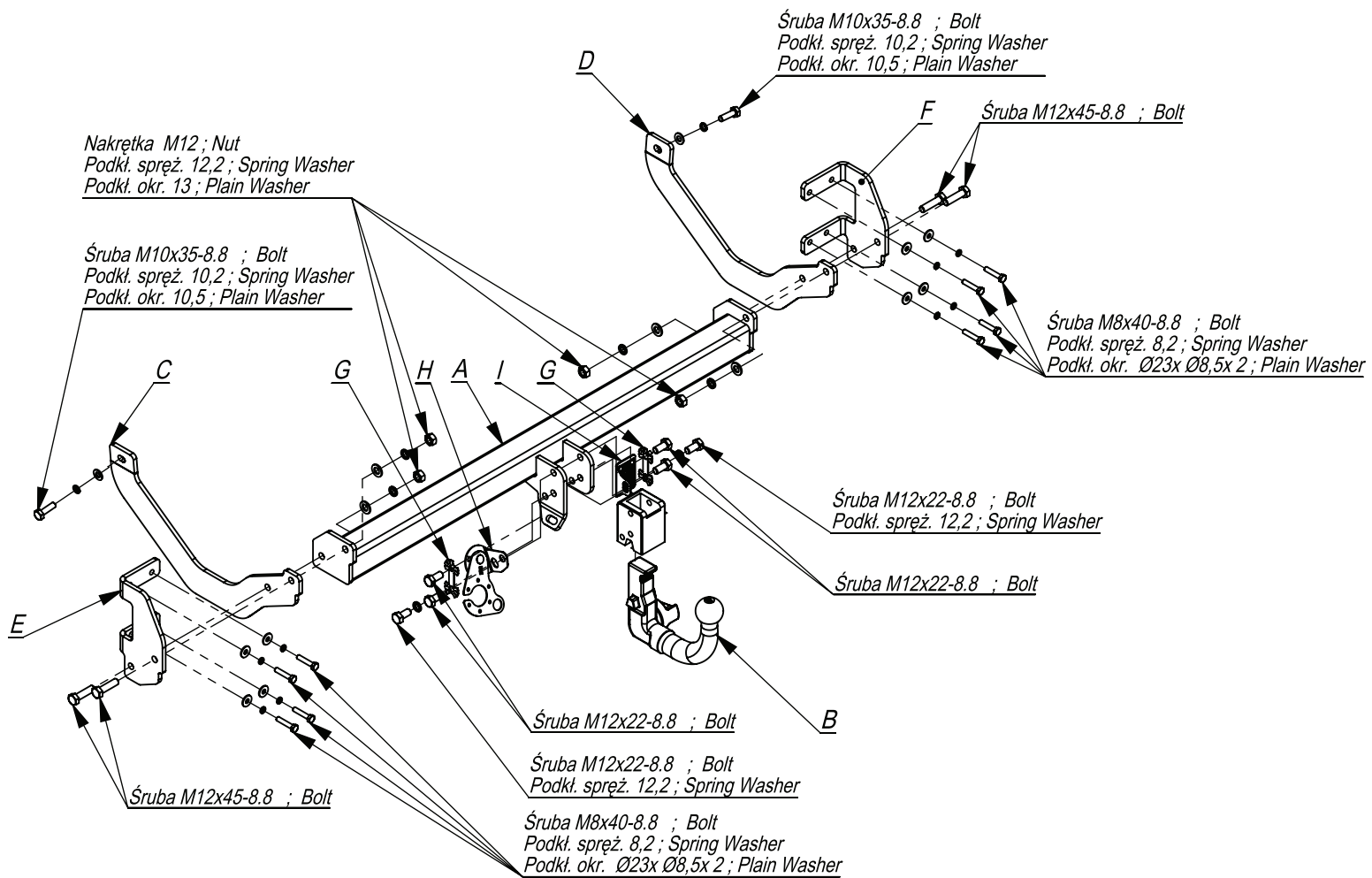

| | | | | | |
|--|---|----|--|------------|---|
| | A | x1 | | M12x45 | 4 |
| | | | | M12x22 | 6 |
| | | | | M10x35 | 2 |
| | | | | M8x40 | 8 |
| | B | x1 | | M12 | 4 |
| | C | x1 | | Ø23xØ8,5x2 | 8 |
| | D | x1 | | 13 | 4 |
| | E | x1 | | 10,5 | 2 |
| | F | x1 | | 12,2 | 6 |
| | G | x2 | | 10,2 | 2 |
| | H | x1 | | 8,2 | 8 |
| | I | x1 | | | |

Śruba M10x35-8.8 ; Bolt
Podkt. spręż. 10,2 ; Spring Washer
Podkt. okr. 10,4 ; Plain Washer

Śruba M12x45-8.8 ; Bolt

Pkt. 2

D

Nakrętka M12 ; Nut
Podkt. spręż. 12,2 ; Spring Washer
Podkt. okr. 13 ; Plain Washer

Śruba M10x35-8.8 ; Bolt
Podkt. spręż. 10,2 ; Spring Washer
Podkt. okr. 10,4 ; Plain Washer

Śruba M8x40-8.8 ; Bolt
Podkt. spręż. 8,2 ; Spring Washer
Podkt. okr. Ø23x Ø8,5x 2 ; Plain Washer

Pkt. 1

H A I G

G

C

Pkt. 3

Pkt. 1

Pkt. 2

Śruba M12x22-8.8 ; Bolt
Podkt. spręż. 12,2 ; Spring Washer

Śruba M12x22-8.8 ; Bolt

Marka

Peugeot 508 SW kombi od 03/2011 ->

Nr katalogowy
P/A38

Śruba M12x22-8.8 ; Bolt
Podkt. spręż. 12,2 ; Spring Washer

Śruba M8x40-8.8 ; Bolt
Podkt. spręż. 8,2 ; Spring Washer
Podkt. okr. Ø23x Ø8,5x 2 ; Plain Washer

Śruba M12x45-8.8 ; Bolt



96-111 Kowiesy, Chojnata 23 A
tel. +48 46 831 73 31

- Odkręcić lampy i zderzak.
- Odkręcić wypełnienie belki zderzeniowej
- Przykręcić elementy E i F do tylnego pasa śrubami M8x40 8.8 (pkt 2).
- Przykręcić elementy C i D do podłużnic śrubami M10x35 (pkt 3).
- Przykręcić belkę haka A śrubami M12x45 8.8 (pkt 1) z elementami E i F oraz C i D.
- Wykonać wycięcie w osi, w dolnej części zderzaka na uchwyty kuli.
- Przykręcamy wypełnienie belki zderzeniowej, lampy i zderzak.
- Dokręcić wszystkie śruby z momentem według tabeli.
- Dokręcić kulę i blachę gniazda elektrycznego.
- Podłączyć instalację elektryczną.

- Disassemble the rear lamps and bumper.
- Unscrew the bumper bar filler.
- Screw the elements E and F to the rear belt with bolts M8x40 8.8 (point 2).
- Screw the elements C and D to the frame side members with bolts M10x35 8.8 (point 3).
- Screw the main bar A with bolts M12x45 8.8 (point 1) together with the elements E, F and C, D.
- Cut out the fragment in the lower part of the bumper, in its axle to put the towball handles.
- Screw the bumper bar filler, bumper and lamps.
- Tighten all the bolts according to the torque setting- see the table.
- Fix the ball and electric plate.
- Connect the electric wires.

- Dévisser le pare-chocs et les lampes.
- Dévisser le remplissage du faisceau de collision.
- Visser les éléments E et F sur la courroie arriere avec des vis M8x40 8.8 (point 2).
- Przykręcić elementy C i D do podłużnic śrubami M10x35 (pkt 3) Visser les éléments C et D aux longerons avec les boulons M10x35 (point 3).
- Fixer la barre a crochet A avec les boulons M12x45 8.8 (point 1) avec les éléments E et F et C et D.
- Faire une encoche dans l'axe, au bas du pare-chocs sur les supports de balle.
- Visser les poutres collision de remplissage, les lumi?res et les pare-chocs.
- Serrer tous les boulons avec un couple de serrage selon tableau.
- Visser la boule et la tôle de la prise électrique.
- Brancher l'installation électrique.

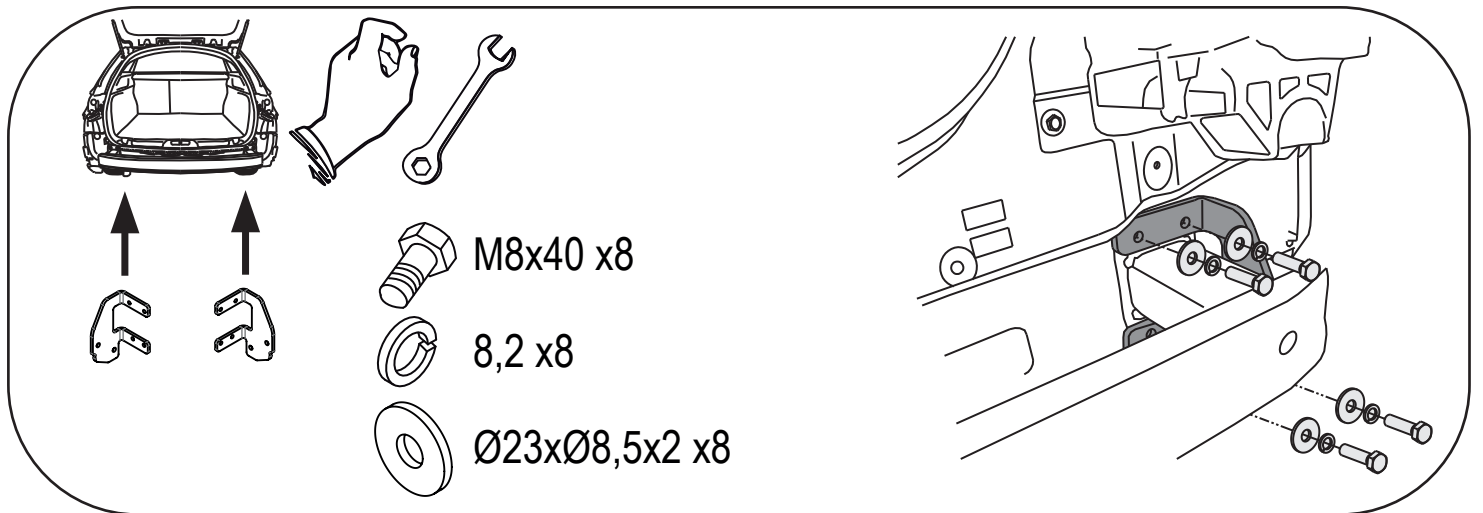
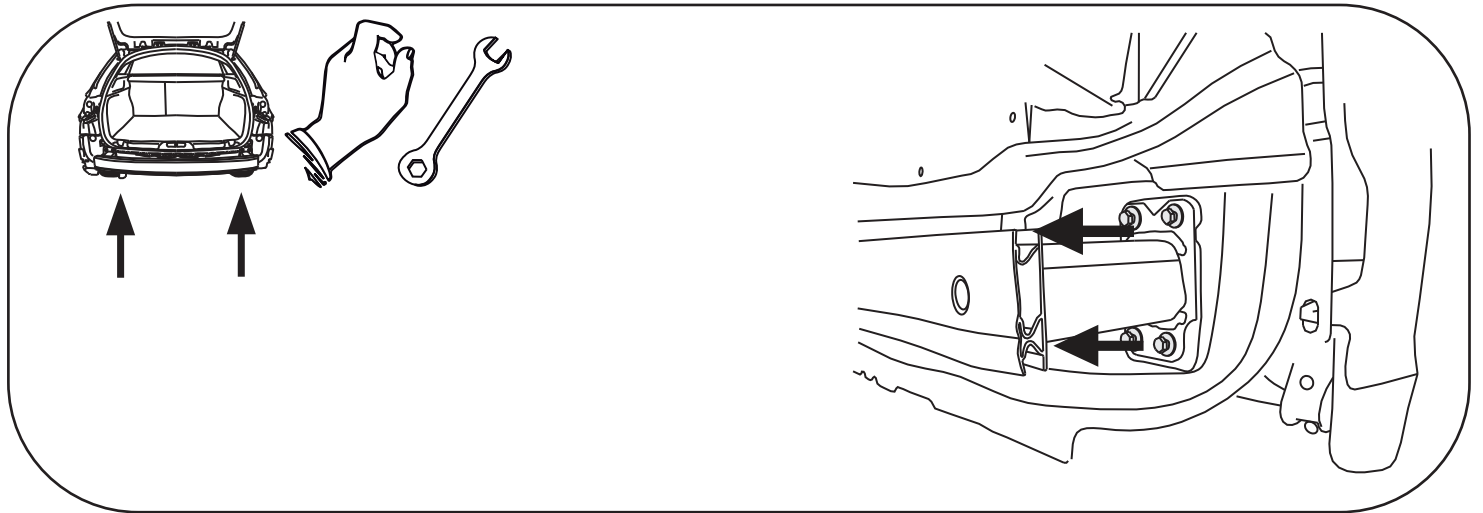
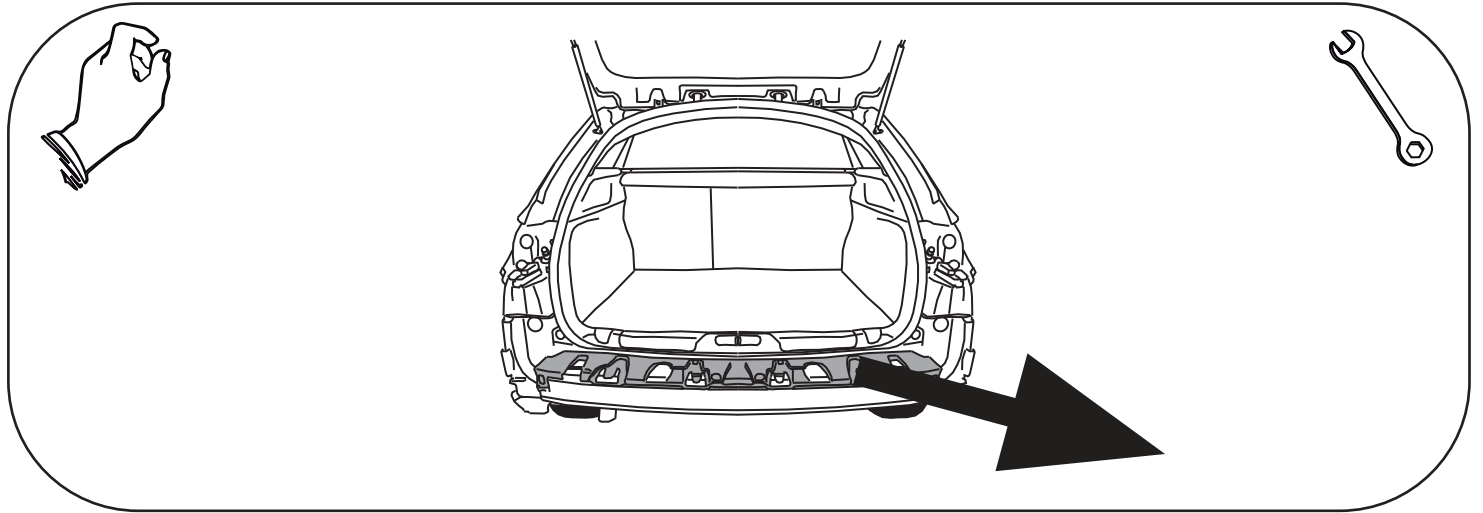
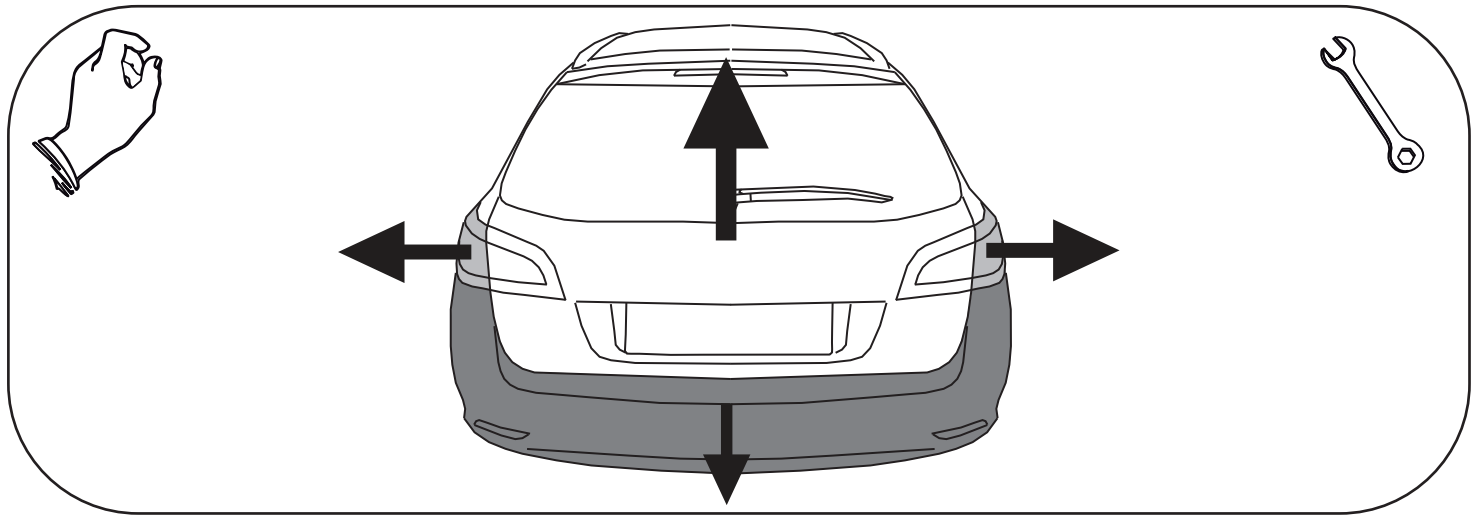

- Die Rückleuchten und den Stoßfänger abschrauben.
- Schrauben Sie die Kollisionsbalkenfüllung ab.
- Die Stoßstange Balken befestigenden Schrauben und das Tragteil E und F mit den Schrauben M8x40 (Punkt 2) abschrauben.
- Die AHK-Bauteile C und D mit Schrauben M10x35 (Punkt 3) an den Längsträgern festschrauben.
- Befestigen Sie die Hakenstange A mit Schrauben M12x45 8.8 (Punkt 1) mit den Elementen E und F und C und D.
- In der Achse des Stoßfängers einen Ausschnitt für die Kugelhalterung ausführen.
- Wir schrauben die Füllung des Aufprallträgers, die Lampe und den Stoßfänger an.
- Ziehen Sie alle Schrauben mit dem Drehmoment gemäß der Tabelle an.
- Die Kugel und den Steckdose-Blech anziehen.
- Die elektrische Installation anschließen.

- Desenrosque las lámparas y el parachoques.
- Desenrosque el relleno del haz de colisión.
- Atornille los elementos E y F a la correa trasera con pernos M8x40 8.8 (punto 2).
- Apretar los elementos C y D a la largueros con tornillos M10x35 (punto 3).
- Fije la barra de gancho A con tornillos M12x45 8.8 (punto 1) con los elementos E, F, C y D.
- Haga una muesca en el eje, en la parte inferior del parachoques en el soporte de bolas.
- Atornillamos el relleno de la viga de impacto, la lámpara y el parachoques.
- Apretar todos los tornillos con el par según la tabla anterior..
- Apretar la bola y la placa de la toma eléctrica.
- Conectar la instalación eléctrica.

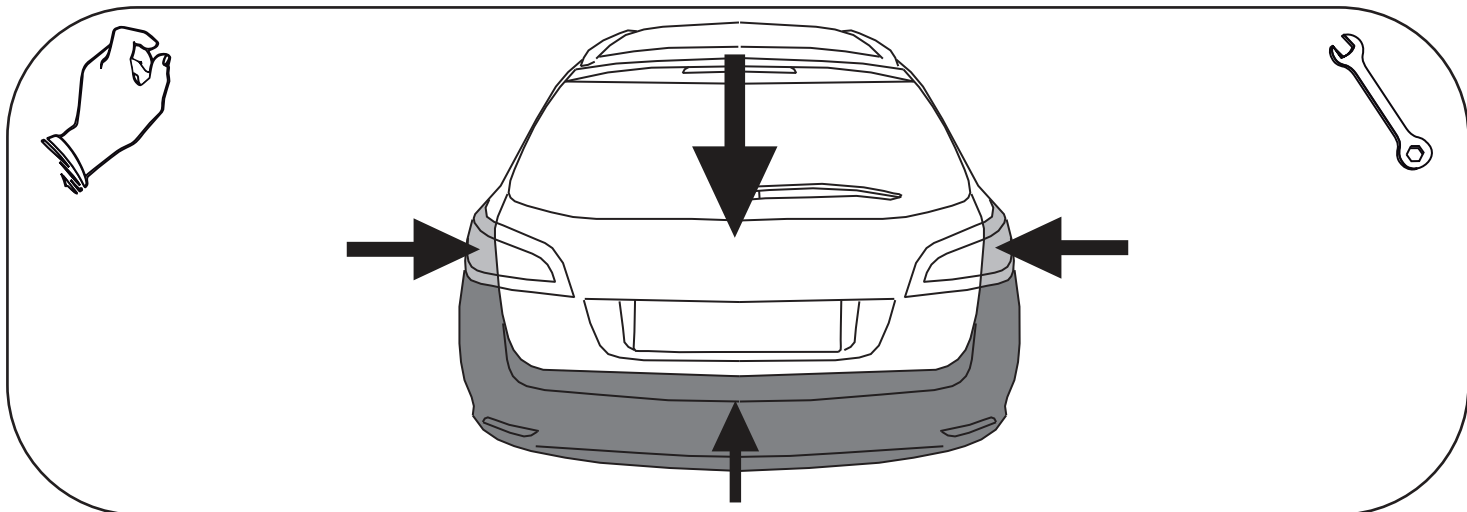
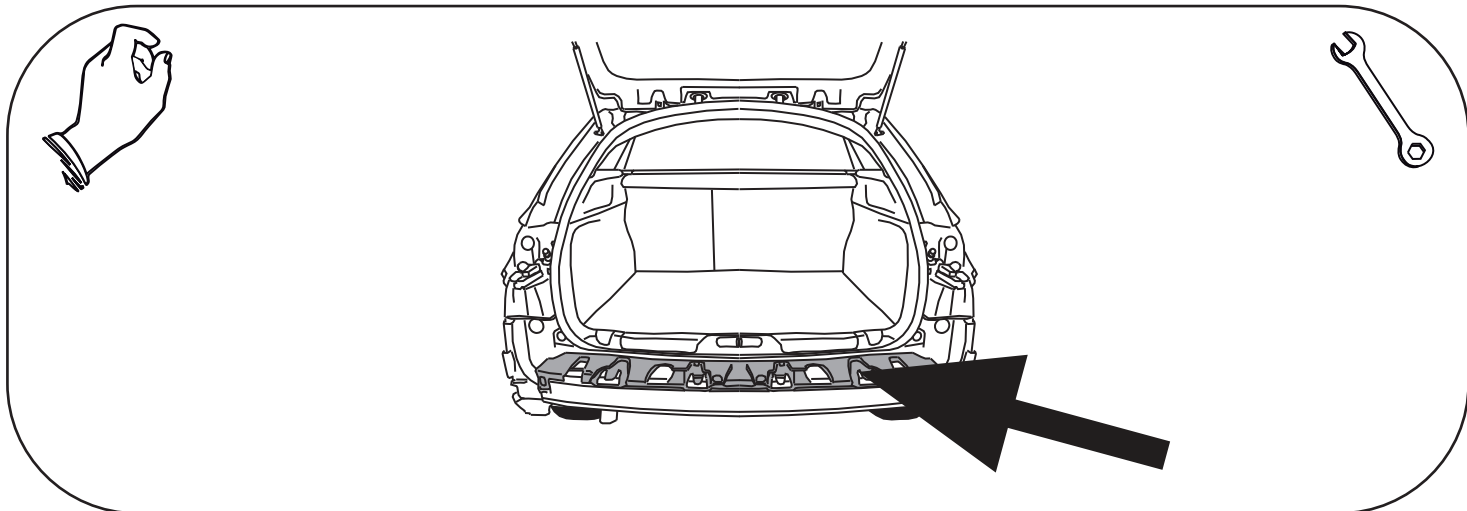
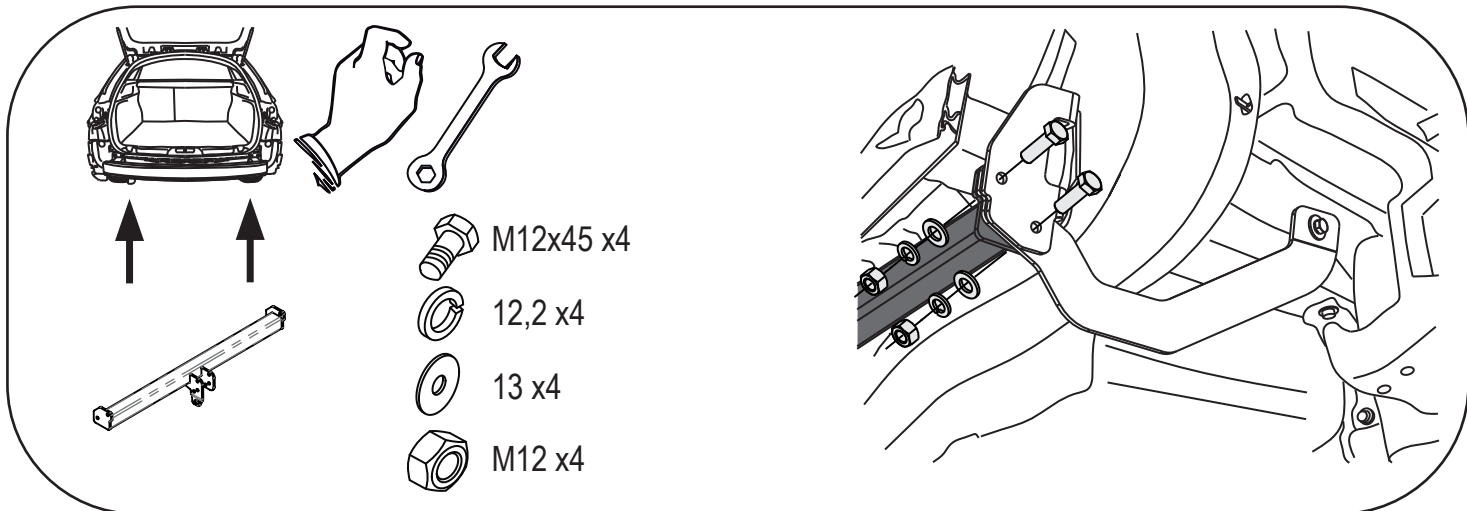
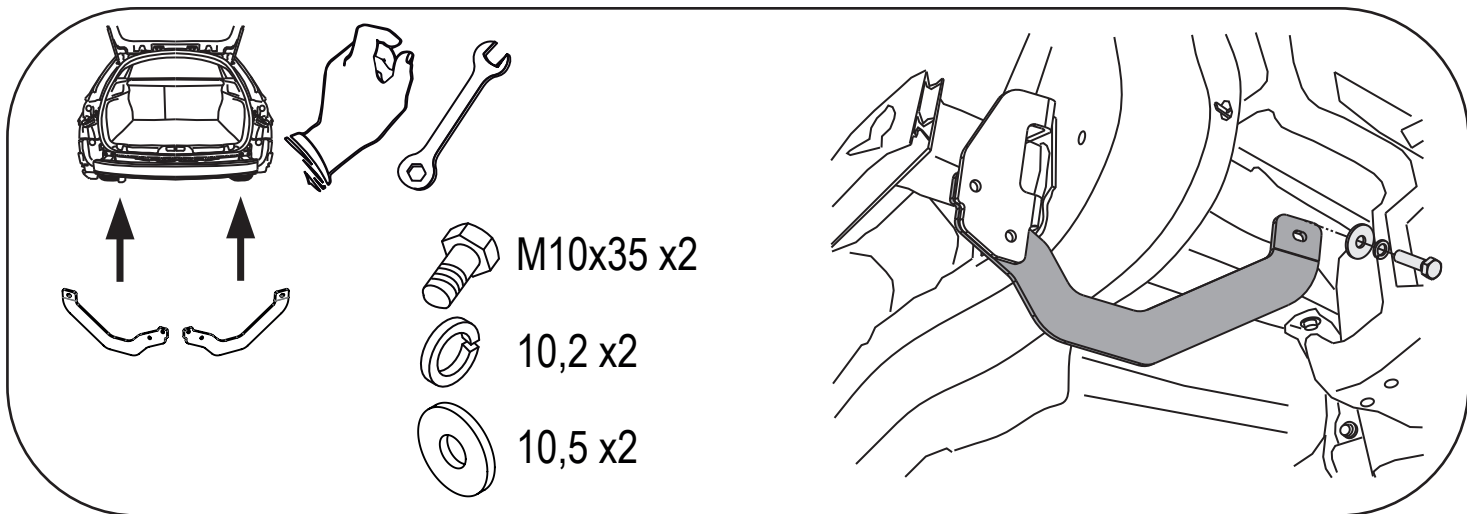

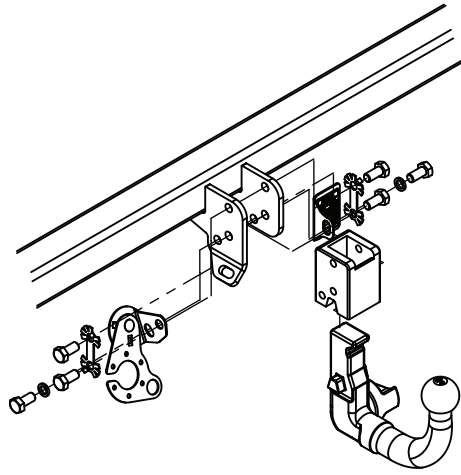
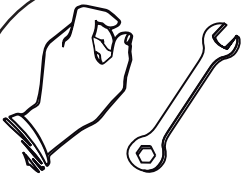



-  M12x22 x6
-  12,2 x2
-  G x2



CRIMP

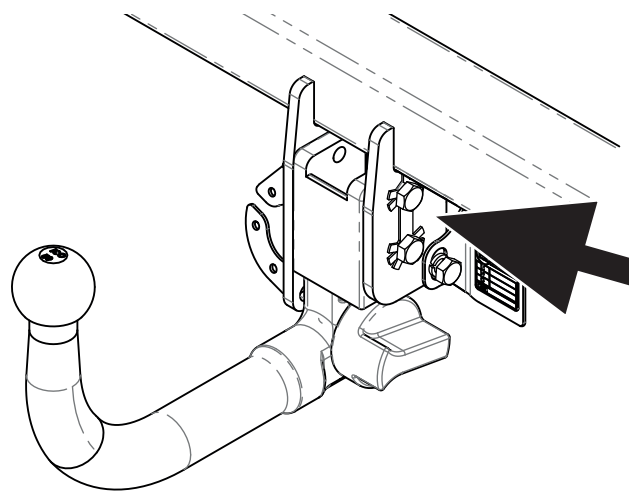
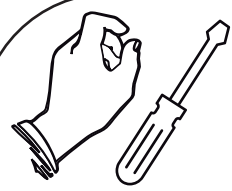
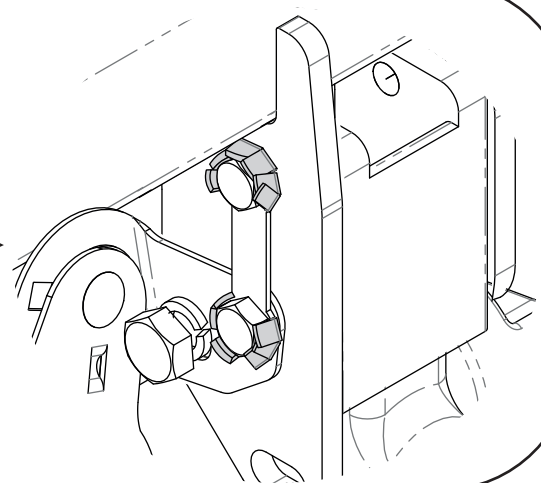
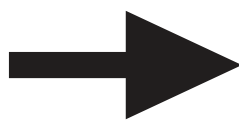
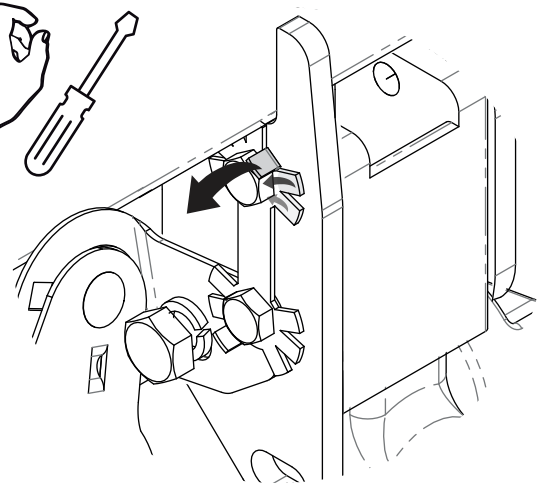
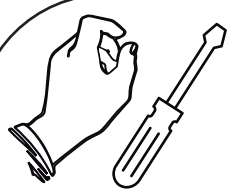
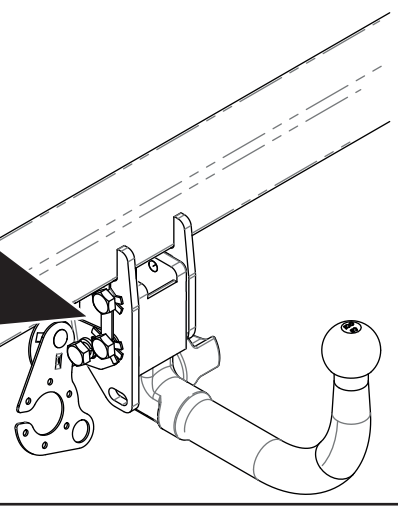

CRIMP

