



TOYOTA COROLLA
com. E12

2002 - 2007

Cat. No. T/019

e20

e20*94/20*0380*00

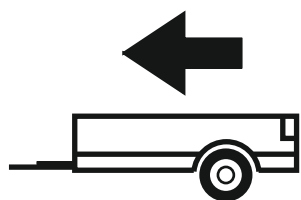

1350kg

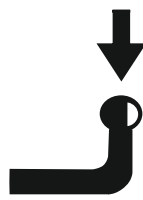

55kg

D = 7,91kN

D (kN) = $\frac{\text{MAX kg} \times \text{MAX kg}}{\text{MAX kg} + \text{MAX kg}} \times 0,00981$



IMIOLA HAK-POL

96-111 KOWIESY, CHOJNATA 23A, POLAND

Tel. + 48 46 831 73 31, fax +48 831 74 29

e-mail: office@imiola.pl, www.imiola.pl

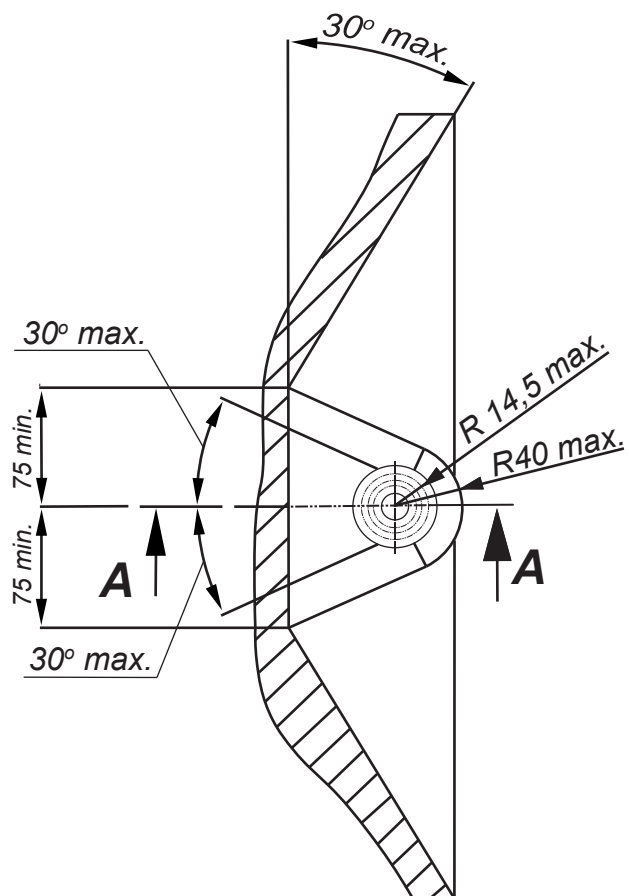

PRZEKRÓJ A-A

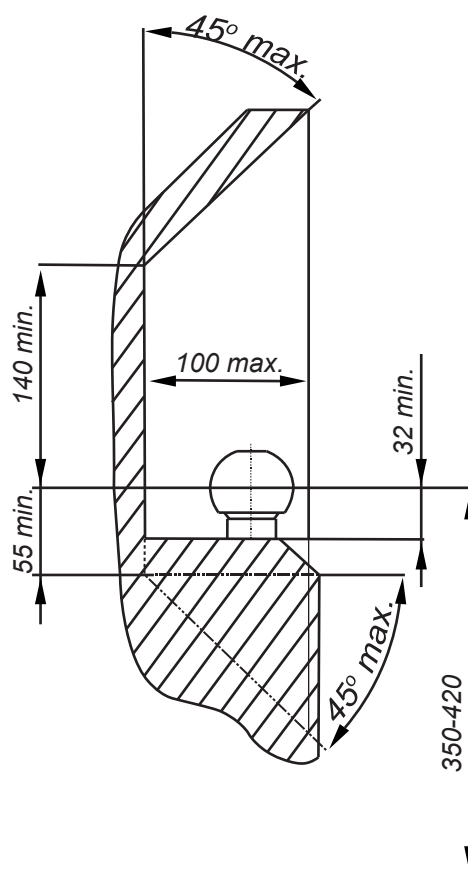

PL Należy zagwarantować przestrzeń swobodną według załącznika VII, rysunek 25a/b Regulaminu EKG ONZ 55.01 przy dopuszczalnym ciężarze całkowitym pojazdu.

F L'espace libre doit être garanti conformément à l'annexe VII, illustration de la réglementation 55.01 CE pour un poids total en charge autorisé du véhicule.







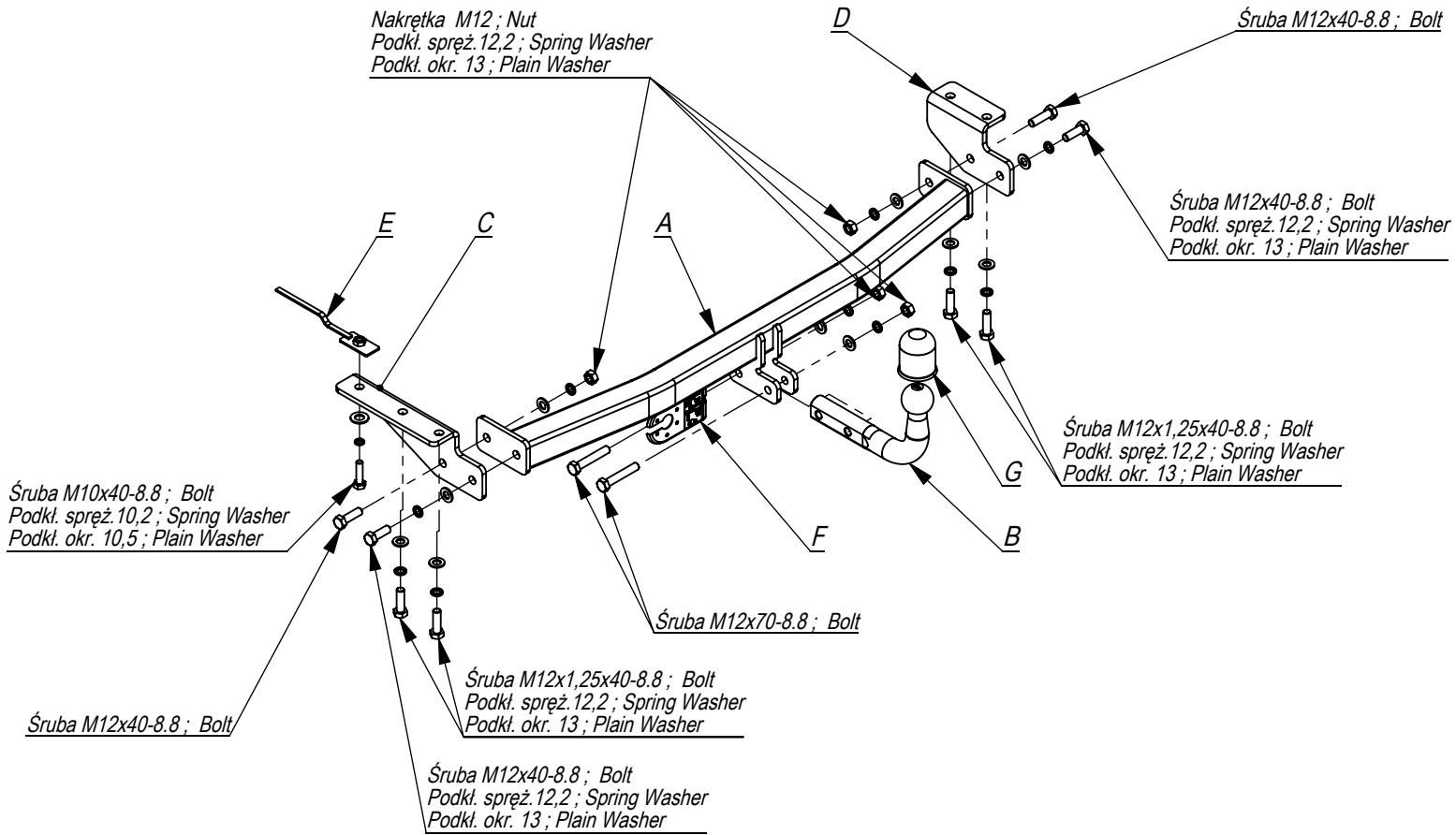

GB The clearance specified in appendix VII, diagram 25a/b of Regulation No. 55.01 UN EU must be guaranteed at laden weight of the vehicle.

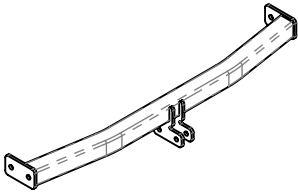
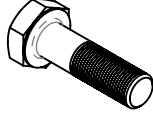
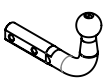
D Der Freiraum nach Anhang VII, Abbildung 25a/b der Vorschriften 55.01 EG ist zu gewährleisten bei zulässigem Gesamtgewicht des Fahrzeuges.

Moment skracający dla śrub i nakrętek (8.8) Torque settings for nuts and bolts (8.8)	
M8	25Nm
M10	55Nm
M12	85Nm
M14	135Nm
M16	195Nm



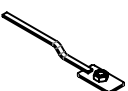

	A	x1		M12x70	2
				M12x1,25x40	4
				M12x40	4
				M10x40	1
	B	x1		M12	4
	C	x1		13	10
				10,5	1
	D	x1		12,2	10
				10,2	1
	E	x1			
	F	x1			
	G	x1			

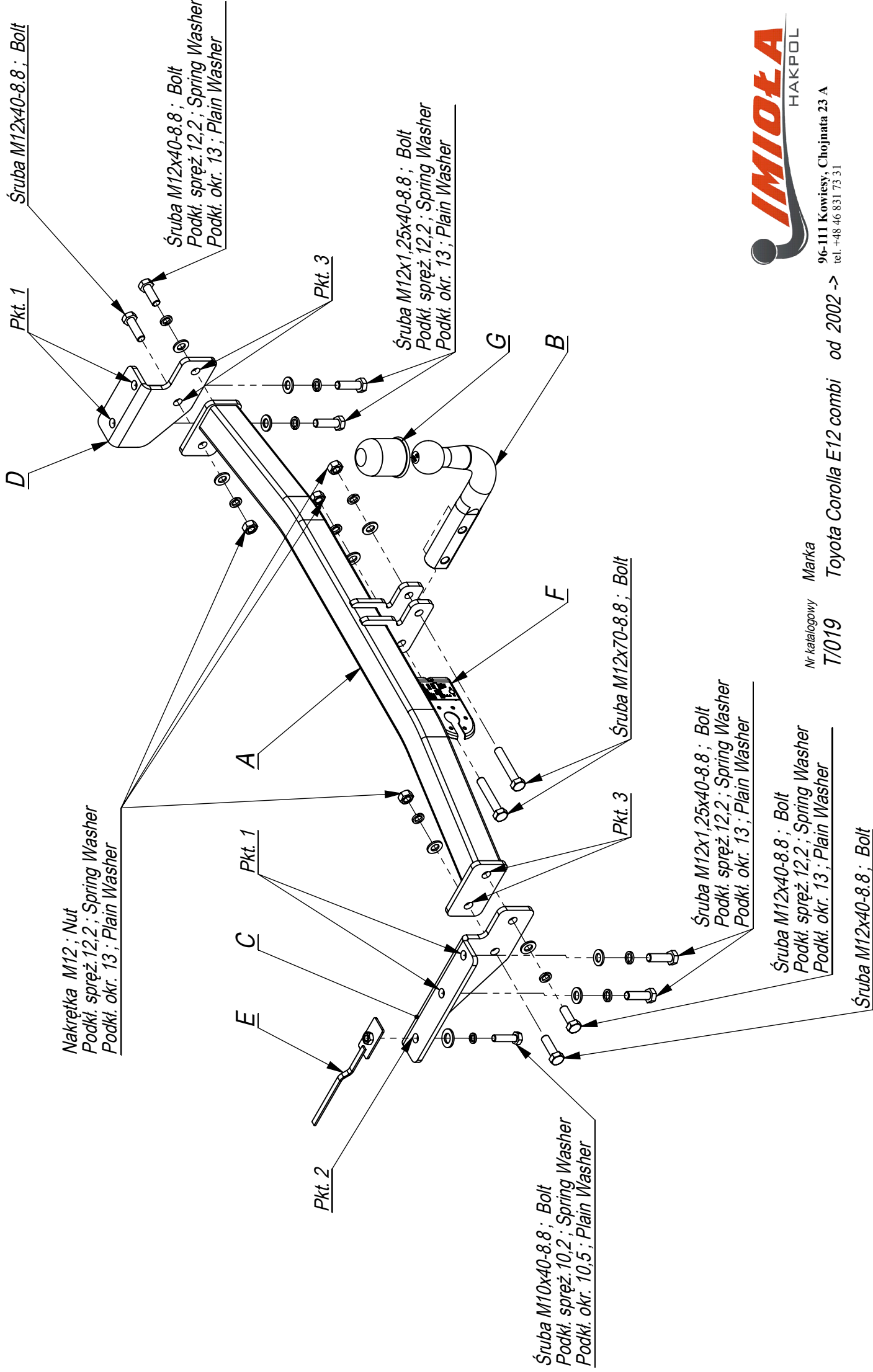

Nakrętka M12; Nut
 Podkl. spręż. 12,2; Spring Washer
 Podkl. okr. 13; Plain Washer

Śruba M12x40-8.8; Bolt

Śruba M12x40-8.8; Bolt
 Podkl. spręż. 12,2; Spring Washer
 Podkl. okr. 13; Plain Washer

Śruba M12x1,25x40-8.8; Bolt
 Podkl. spręż. 12,2; Spring Washer
 Podkl. okr. 13; Plain Washer

Śruba M12x70-8.8; Bolt

Śruba M12x1,25x40-8.8; Bolt
 Podkl. spręż. 12,2; Spring Washer
 Podkl. okr. 13; Plain Washer

Śruba M12x40-8.8; Bolt
 Podkl. spręż. 12,2; Spring Washer
 Podkl. okr. 13; Plain Washer

Śruba M12x40-8.8; Bolt

Śruba M10x40-8.8; Bolt
 Podkl. spręż. 10,2; Spring Washer
 Podkl. okr. 10,5; Plain Washer

Nr katalogowy T/019
 Marka Toyota
 Toyota Corolla E12 combi od 2002 ->



96-111 Kowiesy, Chojnata 23 A
 tel. +48 46 831 73 31

- Odkręcić uszy holownicze (nie będą już wykorzystane).
- Do prawej podłużnicy przykręcić lekko w technologiczne otwory element haka D śrubami M12x40x1,25 8.8 (pkt 1).
- Do lewej podłużnicy przykręcić lekko w technologiczne otwory element haka C śrubami M12x40x1,25 8.8 (pkt 1).
- Poprzez technologiczne otwory w lewej podłużnicy włożyć w podłużnicę płaskownik z przyspawaną nakrętką M10 i przykręcić element C śrubą M10x40 8.8 (pkt 2).
- Do elementów haka C i D przykręcić belkę haka A śrubami M12x35 8.8 (pkt 3).
- Dokręcić wszystkie śruby z momentem według tabeli.
- Przykręcić kulę i podstawę gniazodka elektrycznego śrubami M12x70 8.8.
- Podłączyć instalację elektryczną.

- Unscrew the towing eyes (they will not be used any more).
- Screw slightly element D to the right metal clamp in the technological holes with bolts M10x35x1,25 8.8 (point 1).
- Screw slightly element C to the left metal clamp in the technological holes with bolts M10x35x1,25 8.8 (point 1).
- Place the plate with nut M10 in the metal clamp through the technological holes in the left metal clamp and screw element C with bolt M10x40 8.8 (point 2).
- Screw the main bar A to the elements C and D with bolts M12x35 8.8 (point 3).
- Tighten all the bolts according to the torque setting- see the table.
- Fix the ball and electric plate with bolts M12x70 8.8.
- Connect the electric wires.

- Dévisser les anneaux d'attelage (ils ne seront plus utilisés).
- Visser légèrement l'élément de crochet D dans les trous technologiques du longeron droit, avec les boulons M12x40x1,25 8.8 (pt 1).
- Visser légèrement l'élément de crochet C dans les trous technologiques du longeron gauche, avec les boulons M12x40x1,25 8.8 (pt 1).
- Par les trous technologiques dans le longeron gauche, introduire dans le longeron un méplat avec un écrou M10 soudé, et visser l'élément C avec le boulon M10x40 8.8 (pt 2).
- Visser la poutre du crochet d'attelage A aux éléments C et D avec les boulons M12x35 8.8. (pt 3).
- Serrer tous les boulons avec un couple de serrage selon tableau.
- Visser la boule et la socle de la prise électrique avec les boulons M12x70 8.8.
- Brancher l'installation électrique.

- Die Abschleppösen demontieren.
- An den rechten Längsträger in die vom Werk aus vorhandenen Öffnungen das Tragteil D mit den Schrauben M12x40x1,25 8.8 (Punkt 1) locker anschrauben.
- An den linken Längsträger in die vom Werk aus vorhandenen Öffnungen das Tragteil C mit den Schrauben M12x40x1,25 8.8 (Punkt 1) locker anschrauben.
- Durch die vom Werk aus vorhandenen Öffnungen im linken Längsträger, das Flacheisen mit angeschweißter Mutter M10 in den Längsträger schieben und das Tragteile C mit der Schraube M10x40 8.8 (Punkt 2) anschrauben.
- An die Tragteile C und D den Querbalken A mit den schrauben M12x35 8.8 (Punkt 3) anschrauben.
- Alle Schrauben mit dem in der Tabelle angegebenen Drehmoment festziehen.
- Die Kugel und die Steckdosenhalterung mit den Schrauben M12x70 8.8 anschrauben.
- Die Elektroinstallation anschließen.

- Desatornille la argolla de remolque a la izquierda.
- Fijar los elementos D del gancho a los largueros con tornillos M12x40x1,25 8.8 (punto 3).
- Fijar los elementos C del gancho a los largueros con tornillos M12x1,25x40 (punto 2).
- Atornillar el elemento C usando los tornillos M10x40 (p. 1).
- Fijar el gancho A a los elementos C y D con tornillos M12x40 8.8 (punto 4).
- Atornille la bola y la placa de toma de corriente eléctrica. con tornillos M12x70 8.8.
- Apretar todos los tornillos con el par según la tabla anterior.
- Conectar la instalación eléctrica.

